

# W aluminium motors

Frame sizes 63 to 180



# Specification and Introduction



2

## Specification

Specification	Standard product	Option
<b>Frame sizes</b>	63 - 180	
<b>Enclosure</b>	IP55	IP56, IP65, IP66
<b>Mounting option</b>	Foot (B3), Flange (B5), Face (B14) or Pad (B30)	Foot & Flange (B35), Foot & Face (B34)
<b>Terminal box position</b>	Top	Right hand side, left hand side
<b>Voltage</b>	3 kW and below: 230 / 400	-
	4 kW and above: 400 / 690	-
<b>Frequency</b>	50 Hz	60 Hz
<b>Cooling</b>	IC411	IC410, IC416 & IC418
<b>Bearing location</b>	Non drive end	Drive end
<b>Lubrication</b>	63 - 180 double-shielded bearings	-
<b>Insulation</b>	class F	class H
<b>Temperature rise</b>	class B	class F
<b>Paint colour</b>	water blue (RAL 5021)	on request
<b>Fan cover</b>	Steel	Plastic
<b>Thermal protection</b>	-	63 - 180
<b>Anti condensation heaters</b>	-	63 - 180
<b>Drain holes</b>	160 - 180	63 - 132
<b>Inverter Duty</b> [with derate]	Variable Torque: 10:1	-
	Constant Torque: 2:1	Alternative speed range
<b>Ambient temperature</b>	-20°C to +40°C	-55°C to +80°C
<b>Brake kit friendly</b>	63 - 132 frames	-
<b>AC &amp; DC brake option</b>	63 - 132	160 - 180

The above specification and options give a brief summary of features available for the W aluminium range. For a full listing of optional features, please contact Brook Crompton sales.

## Brook Crompton

Brook Crompton is a leading supplier of electric motors for the global industrial market, with motor solutions which benefit a wide range of customers.

Our products are used in almost every industrial activity including water treatment, building services, chemical/petrochemicals, general processing and manufacturing where they drive fans, pumps, compressors and conveyors, amongst other things.

Brook Crompton incorporates many well known names including Brook Motors, Crompton Parkinson, Electrodrives, Newman, Bull Electric and Hawker Siddeley Electric Motors.

We have extensive stocks of motors, backed-up by a network of distributors, ensuring excellent local support wherever needed.

## Quality assurance

Stringent quality procedures are observed from first design to finished product in accordance with the ISO9001 quality systems.

All of our factories have been assessed to meet these requirements, a further assurance that only the highest standards of quality are accepted.

## W aluminium range

The Brook Crompton aluminium motor range covers products with outputs from 0.07kW to 22kW in frame sizes WU-DA63S to WU-DA180L. They are widely used in a diverse range of applications from food and drink to water and sewage. From heating and ventilation to refrigeration. Some of the benefits of aluminium over cast iron, include, high resistance to corrosion and atmospheric attack (except chlorine, salt-laden or sulphuric acid) and the fact that aluminium is approximately one third the weight of cast iron.

## Multi-Mount

By simply changing the position of the feet, the user is able to obtain right, left or top mounted terminal box positions and by removing the standard endshield you can change it for a flange or face version.

## Benefits include:

- high efficiency for low running costs
- low noise levels
- Eurovoltage: 400 V  $\pm$ 10% 50 Hz
- 50 Hz and 60 Hz
- high torque with smooth acceleration and low current
- 3-year warranty

## Efficiency

Brook Crompton are an approved manufacturer of ac electric motors within the UK Governments Enhanced Capital Allowance scheme. A wide range of single speed motors are included on the technology list.

Please check the ECA scheme website: [www.eca.gov.uk](http://www.eca.gov.uk) at time of purchase for current listing.

# Standards and environment

## Standards

Standards			
Motors of aluminium construction can be manufactured to the international standards listed below:			
Range	International	UK	Europe
Standard	IEC	BS, EN & IEC	EN & IEC
Outputs	IEC 60034-1	BS EN 50347:2001	EN 50347
Performance	IEC 60034-1	BS EN 50347:2001 BS EN 60034-30	EN 60034-1
Dimensions	IEC 60072-1	BS EN 50347 BS 4999 part 141	EN 50347
Mounting	IEC 60034-7	BS EN 60034-7	EN 60034-7
Degrees of protection	IEC 60034-5	BS EN 60034-5	EN 60034-5

Motors complying with IEC 60034-1 also comply with many of the national standards of other European countries, eg CEI 203 (Italy), NBN7 (Belgium), NEN 3173 (Netherlands), SEN 2601 01 (Sweden)

## Environment Enclosure

All motors have degrees of IP protection as defined in IEC EN 60034-5. The normal arrangement is IP55. See Specification (page 2) for alternatives.

## Motor cooling

Motors are cooled in accordance with IEC 60034-6. The normal arrangement is IC411 (Totally Enclosed Fan Ventilated) via a fan mounted at the non-drive end. See Specification (page 2) for alternatives.

## European directives

The following European directives apply:

### Directives

Compliance with European directives applying to AC induction motors				
Directives	Low voltage (LV)	Machinery (MD)	Electromagnetic compatibility (EMC)	Energy using products (EuP)
<b>Reference numbers</b>	73/23/EEC 93/68/EEC 2006/95/EC	89/392/EEC 93/44/EEC 98/37/EC 98/79/EC 2006/42/EC	89/336/EEC 92/31/EEC 93/68/EEC 2004/108/EC	92/42/EEC 96/57/EC 2000/55/EC 2005/32/EC
<b>Motor CE marked</b>	Yes	No	No	Yes
<b>Standards</b>	EN 60034	Not applicable	EN 60034-1	EN 60034-30
<b>Documentation for customers' technical file</b>	Declaration of conformity	Certificate of incorporation	Statement <sup>(1)</sup>	Declaration of conformity
<b>Safety instructions with every motor</b>	Yes	Yes	Yes	-
<b>Comment</b>	Relevant electrical equipment operating between 50 to 1000 volts AC	Statement <sup>(2)</sup>	Component	Minimum efficiency levels for motor outputs 0.75 - 375kW 2-6 pole

<sup>(1)</sup> Motors operating from a correctly applied, sinusoidal (AC) supply meet the requirements of the EMC directive and are within the limits specified in standard EN 60034-1

<sup>(2)</sup> When installed in accordance with our customer safety and installation and maintenance instructions, they can be put into service only when the machinery into which they are being incorporated, has been declared to be in conformity with the machinery directive in accordance with Article 4(2) and Annex IIB of that Directive (98/37/EEC)

## Minimum Energy Performance Standard

### The new standard

The EU MEPS scheme sets new **mandatory** minimum efficiency levels for most single speed 3ph induction motors up to 375kW rated up to 1000V, unlike the narrow definition of the CEMEP voluntary scheme which only covered a small number of standard motors.

The Voluntary Agreement, since 1998, of CEMEP for motor manufactures has expired (classes EFF3 /EFF2/EFF1).

The new standard for motors is now **mandatory** regulation in Europe.

The scope of EU MEPS covers 2, 4 & 6 pole single speed 3ph induction motors from 0.75 to 375kW, rated up to 1000V based on continuous duty operation.

Aiming to reduce energy consumption throughout Europe and the rest of the world, it comes into effect in 3 stages. The effect of this is to maximise potential savings in electric motor driven systems. Base of the regulation is a new international IEC 60034-30 standard. It defines the following efficiency classes :

- IE1** - Standard Efficiency (comparable to EFF2)
- IE2** - High Efficiency (comparable to EFF1 and USA EPACT 60 Hz)
- IE3** - Premium Efficiency (comparable to USA "NEMA Premium" 60 Hz)

## New Efficiency levels in Europe (Time Line)

### Mandatory from:

Since 16 June 2011:

Minimum efficiency requirement at IE2 for all motors covered 0.75 - 375kW

From 1 January 2015:

Minimum efficiency requirement at IE3 level for 7.5 - 375kW motors or IE2 level for motors equipped with an appropriate variable speed drive.

From 1 January 2017:

Minimum efficiency requirement at IE3 level for 0.75 - 375kW motors or IE2 level for motors equipped with an appropriate variable speed drive.

# Performance data



## 4 3000 min<sup>-1</sup> (2 pole)

Rated power $P_N$ kW (hp)	Full load speed in revolutions per minute $n$ min <sup>-1</sup>	Frame reference and size Type	IE3	Full load current at rated voltage $I_N$			Efficiency $\eta$		Power factor $\cos \phi$	Full load torque $M_N$ Nm	Direct on line starting torque ratio $\frac{M_A}{M_N}$	Direct on line starting current ratio $\frac{I_A}{I_N}$	Direct on line pull out torque ratio $\frac{M_K}{M_N}$	Direct on line pull up torque ratio $\frac{M_S}{M_N}$	Star delta starting torque ratio (i) $\frac{M_A}{M_N}$ Y	Star delta starting torque ratio (ii) $\frac{I_A}{I_N}$ Y	Star delta starting current ratio $\frac{M_S}{M_N}$ Y	Rotor inertia Wk <sup>2</sup> J kgm <sup>2</sup>	Mean sound pressure level @ 1m on no load $L_{PA}$ dB(A)
				230 V A	400 V A	690 V A	$1.0 P_N$ $0.75 P_N$ $0.5 P_N$	$1.0 P_N$ $0.75 P_N$ $0.5 P_N$											
0.75 (1.0)	2890	WP-DA80MM	IE3	2.7	1.55	-	<b>80.7</b> 81.0 77.0	<b>0.86</b> 0.80 0.68	2.5	3.3	7.7	3.1	2.5	-	-	-	0.0013	56	
1.1 (1.5)	2885	WP-DA80MS	IE3	3.95	2.30	-	<b>83.5</b> 84.8 83.5	<b>0.84</b> 0.78 0.66	3.6	3.5	7.7	3.1	2.8	-	-	-	0.0013	56	
1.5 (2.0)	2880	WP-DA90LMX	IE3	5.25	3.0	-	<b>84.2</b> 84.5 82.0	<b>0.86</b> 0.81 0.70	5.0	3.4	8.2	3.6	3.2	-	-	-	0.0014	66	
2.2 (3.0)	2895	WP-DA90LSX	IE3	7.9	4.6	-	<b>85.9</b> 85.9 84.2	<b>0.81</b> 0.73 0.59	7.3	3.8	8.5	4.1	3.6	-	-	-	0.0016	66	
3 (4.0)	2880	WP-DA100LMF	IE3	9.7	5.6	-	<b>87.1</b> 88.7 88.7	<b>0.93</b> 0.90 0.84	9.9	3.0	8.2	3.3	2.8	-	-	-	0.0058	60	
4 (5.5)	2895	WP-DA112MR	IE3	-	7.3	4.2	<b>88.5</b> 89.2 88.5	<b>0.90</b> 0.85 0.74	13.2	3.9	10	4.8	3.8	1.2	3.1	1.2	0.0064	60	
5.5 (7.5)	2930	WP-DA132SGX	IE3	-	10.6	6.1	<b>90.5</b> 90.5 88.8	<b>0.83</b> 0.76 0.63	17.9	3.9	10	4.8	3.6	1.2	3.1	1.1	0.0144	66	
7.5 (10)	2930	WP-DA132SMX	IE3	-	13.7	7.9	<b>91.0</b> 91.2 90.3	<b>0.87</b> 0.81 0.70	24.5	3.6	9.6	4.3	3.3	1.1	3.0	1.0	0.018	66	
11 (15)	2945	WP-DA160MJ	IE3	-	19.6	11.3	<b>92.2</b> 92.5 91.5	<b>0.88</b> 0.85 0.77	35.7	3.6	7.6	3.6	1.8	1.1	2.4	0.6	0.045	68	
15 (20)	2940	WP-DA160MR	IE3	-	26.0	15.0	<b>93.0</b> 93.3 93.1	<b>0.90</b> 0.87 0.79	48.7	2.2	8.6	3.7	1.9	0.7	2.7	0.6	0.056	68	
18.5 (25)	2955	WP-DA160LT	IE3	-	32.5	18.8	<b>93.3</b> 93.4 92.5	<b>0.88</b> 0.84 0.75	59.8	2.7	9.0	4.0	2.2	0.84	2.8	0.7	0.063	68	
22 (30)	2950	WP-DA180MF	IE3	-	38.1	22.1	<b>93.6</b> 93.6 93.1	<b>0.89</b> 0.85 0.77	71.3	2.2	9.5	4.0	2.1	0.7	3.0	0.7	0.09	68	

# Performance data



3000 min<sup>-1</sup> (2 pole)

Rated power $P_N$ kW (hp)	Full load speed in revolutions per minute $n$ min <sup>-1</sup>	Frame reference and size Type	Full load current at rated voltage $I_N$			Efficiency $\eta$		Power factor $\cos \phi$	Full load torque $M_N$ Nm	Direct on line starting torque ratio $\frac{M_A}{M_N}$	Direct on line starting current ratio $\frac{I_A}{I_N}$	Direct on line pull out torque ratio $\frac{M_K}{M_N}$	Direct on line pull up torque ratio $\frac{M_S}{M_N}$	Star delta starting torque ratio (i) $\frac{M_A}{M_N}$ Y	Star delta starting torque ratio (ii) $\frac{I_A}{I_N}$ Y	Star delta starting current ratio $\frac{M_S}{M_N}$ Y	Rotor inertia Wk <sup>2</sup> J kgm <sup>2</sup>	Mean sound pressure level @ 1m on no load $L_{PA}$ dB(A)
			230 V A	400 V A	690 V A	$\frac{1.0 P_N}{0.75 P_N}$ $\frac{1.0 P_N}{0.5 P_N}$	$\frac{1.0 P_N}{0.75 P_N}$ $\frac{1.0 P_N}{0.5 P_N}$											
0.18 (0.25)	2810	WU-DA63SF	1.07	0.62	-	<b>60.0</b> 55.0 46.0	<b>0.70</b> 0.61 0.50	0.61	1.9	3.5	2.4	1.7	-	-	-	0.0005	52	
0.25 (0.33)	2810	WU-DA63SG	1.25	0.72	-	<b>64.0</b> 63.0 57.0	<b>0.78</b> 0.68 0.57	0.85	2.3	4.5	2.5	2.1	-	-	-	0.00063	52	
0.37 (0.5)	2815	WU-DA71SG	1.52	0.88	-	<b>72.0</b> 73.0 71.0	<b>0.84</b> 0.76 0.63	1.26	1.8	5.0	2.1	1.6	-	-	-	0.00052	51	
0.55 (0.75)	2820	WU-DA71SK	2.13	1.23	-	<b>74.0</b> 75.0 73.0	<b>0.87</b> 0.81 0.70	1.86	1.9	5.0	2.1	1.6	-	-	-	0.00063	51	
0.75 (1.0)	2880	WU-DA80MJ	IE2	2.85	1.65	-	<b>77.4</b> 76.9 75.2	<b>0.84</b> 0.78 0.66	2.5	3.0	7.1	2.7	2.4	-	-	-	0.0010	56
1.1 (1.5)	2880	WU-DA80MM	IE2	4.20	2.35	-	<b>79.6</b> 80.7 78.6	<b>0.84</b> 0.77 0.65	3.6	2.8	6.7	2.7	2.4	-	-	-	0.0013	56
1.5 (2.0)	2850	WU-DA90SMX	IE2	5.15	2.97	-	<b>81.3</b> 82.3 82.6	<b>0.90</b> 0.84 0.76	5.0	2.8	7.1	3.1	2.4	-	-	-	0.0014	66
2.2 (3.0)	2890	WU-DA90LSX	IE2	8.0	4.6	-	<b>83.2</b> 85.4 84.1	<b>0.82</b> 0.72 0.58	7.3	2.5	7.3	3.0	2.5	-	-	-	0.0016	66
3 (4.0)	2890	WU-DA100LR	IE2	10.2	5.9	-	<b>84.6</b> 82.7 75.2	<b>0.88</b> 0.74 0.54	9.9	3.1	8.1	3.1	2.4	-	-	-	0.0050	60
4 (5.5)	2870	WU-DA112MM	IE2	-	7.3	4.2	<b>85.8</b> 89.2 87.4	<b>0.91</b> 0.88 0.81	13.3	3.0	7.8	3.1	2.8	0.93	2.4	0.87	0.0055	60
5.5 (7.5)	2910	WU-DA132SEX	IE2	-	10.2	5.9	<b>87.0</b> 88.8 87.9	<b>0.89</b> 0.83 0.70	18.0	2.7	8.2	3.1	2.4	0.84	2.6	0.75	0.012	66
7.5 (10)	2900	WU-DA132SJX	IE2	-	13.5	7.8	<b>88.1</b> 88.4 88.5	<b>0.91</b> 0.88 0.82	24.7	2.5	8.2	3.0	2.3	0.78	2.6	0.72	0.015	66
11 (15)	2940	WU-DA160MB	IE2	-	20.0	11.5	<b>89.4</b> 89.7 88.5	<b>0.89</b> 0.84 0.76	35.7	2.2	7.8	3.0	1.8	0.68	2.4	0.56	0.039	68
15 (20)	2940	WU-DA160MJ	IE2	-	26.6	15.4	<b>90.3</b> 89.8 88.8	<b>0.90</b> 0.86 0.79	48.7	2.2	8.0	3.1	1.9	0.68	2.5	0.60	0.045	68
18.5 (25)	2930	WU-DA160LR	IE2	-	32.5	18.8	<b>90.9</b> 90.6 89.8	<b>0.90</b> 0.86 0.80	60.3	2.4	8.7	3.2	1.9	0.75	2.7	0.60	0.056	68
22 (30)	2950	WU-DA180ME	IE2	-	39.0	25.5	<b>91.3</b> 91.5 90.4	<b>0.89</b> 0.86 0.76	71.2	2.2	9.0	3.1	1.9	0.68	2.8	0.60	0.084	68

IE2 efficiency 0.75 to 22kW

# Performance data



6

1500 min<sup>-1</sup> (4 pole)

P <sub>N</sub> kW (hp)	n min <sup>-1</sup>	Type	Frame reference and size	Full load current at rated voltage			Efficiency $\eta$	Power factor Cos $\phi$	Full load torque M <sub>N</sub> Nm	Direct on line starting torque ratio $\frac{M_A}{M_N}$	Direct on line starting current ratio $\frac{I_A}{I_N}$	Direct on line pull out torque ratio $\frac{M_K}{M_N}$	Direct on line pull up torque ratio $\frac{M_S}{M_N}$	Star delta starting torque ratio (i) $\frac{M_A}{M_N}$ Y	Star delta starting torque ratio (ii) $\frac{I_A}{I_N}$ Y	Star delta starting current ratio $\frac{M_S}{M_N}$ Y	Rotor inertia Wk <sup>2</sup> J kgm <sup>2</sup>	Mean sound pressure level @ 1m on no load L <sub>PA</sub> dB(A)
				230 V A	400 V A	690 V A												
0.75 (1)	-	tbc	IE3	-	-	-	{ - - }	-	-	-	-	-	-	-	-	-	-	-
1.1 (1.5)	1430	WP-DA90LTX	IE3	4.2	2.5	-	{ 84.1 0.77 84.4 0.70 84.0 0.57 }	7.4	3.0	7.0	3.5	2.7	-	-	-	0.0037	48	
1.5 (2)	1440	WP-DA90LWX	IE3	6.3	3.6	-	{ 85.3 0.70 85.3 0.58 83.2 0.46 }	10.0	4.2	7.4	4.7	4.1	-	-	-	0.0042	48	
2.2 (3)	1450	WP-DA100LRF	IE3	8.1	4.6	-	{ 86.7 0.79 87.0 0.70 86.0 0.57 }	14.5	3.3	7.3	3.3	3.0	-	-	-	0.0106	54	
3 (4.0)	1460	WP-DA100LTF	IE3	11.6	6.7	-	{ 87.7 0.74 87.7 0.63 85.8 0.50 }	19.6	3.7	8.1	3.8	2.8	-	-	-	0.0121	54	
4 (5.5)	1450	WP-DA112MWX	IE3	-	8.4	4.8	{ 88.6 0.78 88.6 0.70 88.0 0.56 }	26.4	3.5	8.0	3.5	2.9	1.1	2.5	0.9	0.0151	54	
5.5 (7.5)	1460	WP-DA132STX	IE3	-	10.9	6.3	{ 89.6 0.81 90.0 0.73 88.7 0.60 }	36.0	3.3	8.7	3.9	2.7	1.0	2.7	0.85	0.030	59	
7.5 (10)	1450	WP-DA132MXV	IE3	-	14.6	8.5	{ 90.4 0.82 91.3 0.73 90.4 0.60 }	49.4	3.2	7.6	3.4	2.6	1.0	2.4	0.8	0.033	59	
11 (15)	1475	WP-DA160MR	IE3	-	20.9	12.1	{ 92.5 0.82 92.8 0.75 92.0 0.62 }	71.3	3.0	9.0	3.7	2.4	0.9	2.8	0.75	0.086	63	
15 (20)	1475	WP-DA160LU	IE3	-	28.1	16.3	{ 92.8 0.83 93.0 0.76 92.3 0.62 }	97.2	3.2	9.1	3.5	2.4	1.0	2.8	0.75	0.1	63	
18.5 (25)	1475	WP-DA180ME	IE3	-	34.7	20.1	{ 92.6 0.83 92.8 0.74 92.0 0.60 }	120	2.8	8.4	3.0	2.0	0.88	2.6	0.6	0.16	62	
22 (30)	1470	WP-DA180LM	IE3	-	41.1	23.8	{ 93.0 0.83 93.0 0.75 93.0 0.62 }	143	3.1	8.8	3.0	2.0	0.97	2.8	0.6	0.122	62	

# Performance data



1500 min<sup>-1</sup> (4 pole)

Rated power $P_N$ kW (hp)	Full load speed/in revolutions per minute $n$ min <sup>-1</sup>	Frame reference and size Type	Full load current at rated voltage $I_N$			$\eta$ 1.0 $P_N$ 0.75 $P_N$ 0.5 $P_N$	Cos $\phi$ 1.0 $P_N$ 0.75 $P_N$ 0.5 $P_N$	Efficiency	Power factor	Full load torque $M_N$ Nm	Direct on line starting torque ratio $M_A$ $M_N$	Direct on line starting current ratio $I_A$ $I_N$	Direct on line pull out torque ratio $M_K$ $M_N$	Direct on line pull up torque ratio $M_S$ $M_N$	Star delta starting torque ratio (i) $M_A$ $M_N$ Y	Star delta starting current ratio (i) $I_A$ $I_N$ Y	Star delta starting current ratio $M_S$ $M_N$ Y	Rotor inertia Wk <sup>2</sup> J kgm <sup>2</sup>	Mean sound pressure level @ 1m on no load $L_{PA}$ dB(A)
			230 V A	400 V A	690 V A														
0.12 (0.166)	1360	WU-DA63SF	0.81	0.47	-	<b>59.0</b> 52.0 42.0	<b>0.62</b> 0.53 0.40	0.85	1.9	2.75	2.0	1.65	-	-	-	0.0005	39		
0.18 (0.25)	1370	WU-DA63SG	1.10	0.63	-	<b>62.0</b> 58.0 51.0	<b>0.66</b> 0.56 0.44	1.25	2.2	3.1	2.2	2.0	-	-	-	0.00063	39		
0.25 (0.33)	1400	WU-DA71SG	1.39	0.80	-	<b>69.0</b> 68.0 62.0	<b>0.65</b> 0.55 0.44	1.71	1.8	4.0	2.2	1.6	-	-	-	0.00084	38		
0.37 (0.5)	1410	WU-DA71SK	1.92	1.11	-	<b>71.0</b> 69.0 63.0	<b>0.68</b> 0.57 0.45	2.5	1.8	4.0	2.2	1.6	-	-	-	0.00097	38		
0.55 (0.75)	1410	WU-DA80ME	2.74	1.58	-	<b>75.0</b> 75.0 70.0	<b>0.67</b> 0.57 0.45	3.7	2.0	4.2	2.2	1.8	-	-	-	0.0015	47		
0.75 (1)	1440	WU-DA80MS	IE2	3.3	1.9	-	<b>79.6</b> 78.8 77.4	<b>0.72</b> 0.62 0.49	5.0	3.8	6.8	2.4	1.8	-	-	-	0.0019	47	
1.1 (1.5)	1425	WU-DA90SRX	IE2	4.4	2.5	-	<b>81.4</b> 81.5 82.0	<b>0.77</b> 0.78 0.58	7.4	2.3	5.2	2.9	2.3	-	-	-	0.0034	48	
1.5 (2)	1440	WU-DA90LWX	IE2	6.5	3.7	-	<b>82.8</b> 83.0 81.0	<b>0.70</b> 0.58 0.46	9.9	2.6	5.6	3.1	2.4	-	-	-	0.0042	48	
2.2 (3)	1435	WU-DA100LS	IE2	8.9	5.1	-	<b>84.3</b> 83.6 81.4	<b>0.74</b> 0.66 0.53	14.6	3.1	6.6	3.1	2.6	-	-	-	0.0103	54	
3 (4.0)	1445	WU-DA100LTF	IE2	11.9	6.8	-	<b>85.5</b> 83.5 82.6	<b>0.74</b> 0.63 0.50	19.8	3.9	8.5	4.0	2.8	-	-	-	0.0118	54	
4 (5.5)	1440	WU-DA112MT	IE2	-	8.7	5.0	<b>86.6</b> 86.6 85.9	<b>0.77</b> 0.69 0.55	26.5	3.0	7.4	3.1	2.6	0.93	2.3	0.80	0.0118	54	
5.5 (7.5)	1455	WU-DA132STX	IE2	-	11.1	6.4	<b>87.7</b> 88.0 87.2	<b>0.82</b> 0.74 0.63	36.2	2.4	7.1	3.0	2.3	0.75	2.2	0.71	0.030	59	
7.5 (10)	1460	WU-DA132MX	IE2	-	14.7	8.5	<b>88.7</b> 89.4 88.6	<b>0.83</b> 0.76 0.67	49.1	2.9	8.1	3.2	2.5	0.90	2.5	0.78	0.033	59	
11 (15)	1465	WU-DA160MJ	IE2	-	21.0	12.1	<b>89.8</b> 91.0 90.4	<b>0.83</b> 0.78 0.67	71.7	2.5	7.7	2.9	2.0	0.78	2.4	0.63	0.068	63	
15 (20)	1460	WU-DA160LR	IE2	-	28.0	16.2	<b>90.6</b> 91.8 91.6	<b>0.85</b> 0.81 0.71	98.1	2.5	7.7	2.9	2.0	0.78	2.4	0.63	0.084	63	
18.5 (25)	1470	WU-DA180ME	IE2	-	35.0	20.2	<b>91.2</b> 91.8 90.7	<b>0.84</b> 0.77 0.66	120	2.8	8.4	3.2	2.2	0.87	2.6	0.68	0.16	62	
22 (30)	1470	WU-DA180LJ	IE2	-	41.0	23.7	<b>91.6</b> 92.1 91.6	<b>0.86</b> 0.83 0.71	143	2.6	7.6	2.9	2.0	0.81	2.3	0.63	0.19	62	

IE2 efficiency 0.75 to 22kW

# Performance data



8

1000 min<sup>-1</sup> (6 pole)

P <sub>N</sub> kW (hp)	n min <sup>-1</sup>	Type	Frame reference and size	Full load current at rated voltage			Efficiency		Power factor	Full load torque	Direct on line starting torque ratio	Direct on line starting current ratio	Direct on line pull out torque ratio	Direct on line pull up torque ratio	Star delta starting torque ratio (i)	Star delta starting current ratio	Star delta pull up torque ratio	Rotor inertia Wk <sup>2</sup>	Mean sound pressure level @ 1m on no load
				230 V A	400 V A	690 V A	η 1.0 P <sub>N</sub> 0.75 P <sub>N</sub> 0.5 P <sub>N</sub>	η 1.0 P <sub>N</sub> 0.75 P <sub>N</sub> 0.5 P <sub>N</sub>											
			I <sub>N</sub>			Cos φ		M <sub>N</sub> Nm	M <sub>Δ</sub> M <sub>N</sub>	I <sub>Δ</sub> I <sub>N</sub>	M <sub>K</sub> M <sub>N</sub>	M <sub>S</sub> M <sub>N</sub>	M <sub>Δ</sub> M <sub>N</sub> Y	I <sub>Δ</sub> I <sub>N</sub> Y	M <sub>S</sub> M <sub>N</sub> Y	J kgm <sup>2</sup>	L <sub>PA</sub> dB(A)		
0.75 (1)	-	tbc	IE3	-	-	-	{ - - }	-	-	-	-	-	-	-	-	-	-	-	
1.1 (1.5)	-	tbc	IE3	-	-	-	{ - - }	-	-	-	-	-	-	-	-	-	-	-	
1.5 (2)	960	WP-DA100LTF	IE3	7.6	4.4	-	{ 82.5 0.60 82.1 0.48 78.9 0.37 }	14.9	3.5	6.2	4.6	3.6	-	-	-	0.012	58		
2.2 (3)	950	WP-DA112MWX	IE3	10.1	5.8	-	{ 84.3 0.65 84.4 0.58 81.8 0.43 }	21.9	2.8	5.6	3.0	2.4	-	-	-	0.015	54		
3 (4)	970	WP-DA132SMX	IE3	12.5	7.2	-	{ 87.0 0.69 86.7 0.62 83.0 0.43 }	29.5	2.3	6.1	2.5	2.2	-	-	-	0.032	58		
4 (5.5)	960	WP-DA132MTX	IE3	-	9.3	5.8	{ 86.8 0.68 86.5 0.59 83.3 0.49 }	39.8	2.2	5.5	2.5	2.1	0.7	1.7	0.66	0.038	58		
5.5 (7.5)	965	WP-DA132MX	IE3	-	13.3	7.7	{ 90.0 0.68 87.0 0.53 89.3 0.42 }	54.5	2.6	6.5	3.0	1.9	0.8	2.0	0.6	0.041	58		
7.5 (10)	975	WP-DA160MM	IE3	-	16.6	9.6	{ 89.1 0.73 89.1 0.65 89.2 0.56 }	73.5	1.7	5.1	1.6	1.3	0.53	1.6	0.4	0.10	59		
11 (15)	980	WP-DA160LV	IE3	-	23.4	13.6	{ 90.3 0.75 90.3 0.69 90.0 0.53 }	107	2.0	5.7	2.8	1.9	0.63	1.8	0.6	0.12	59		
15 (20)	980	WP-DA180LM	IE3	-	30.4	17.6	{ 91.2 0.78 91.5 0.72 90.5 0.61 }	146	2.0	6.0	2.4	1.5	0.63	1.9	0.5	0.24	59		



# Performance data



9

1000 min<sup>-1</sup> (6 pole)

Rated power $P_N$ kW (hp)	Full load speed in revolutions per minute $n$ min <sup>-1</sup>	Frame reference and size Type	Full load current at rated voltage $I_N$			Efficiency $\eta$ 1.0 $P_N$ 0.75 $P_N$ 0.5 $P_N$	Power factor $\cos \phi$ 1.0 $P_N$ 0.75 $P_N$ 0.5 $P_N$	Full load torque $M_N$ Nm	Direct on line starting torque ratio $\frac{M_A}{M_N}$	Direct on line starting current ratio $\frac{I_A}{I_N}$	Direct on line pull out torque ratio $\frac{M_K}{M_N}$	Direct on line pull up torque ratio $\frac{M_S}{M_N}$	Star delta starting torque ratio (i) $\frac{M_A}{M_N}$ Y	Star delta starting torque ratio (ii) $\frac{I_A}{I_N}$ Y	Star delta starting current ratio $\frac{M_S}{M_N}$ Y	Rotor inertia $Wk^2$ J kgm <sup>2</sup>	Mean sound pressure level @ 1m on no load $L_{PA}$ dB(A)	
			230 V A	400 V A	690 V A													
0.07 (0.094)	880	WU-DA63SG	0.60	0.34	-	<b>47.0</b> 42.0 33.0	<b>0.63</b> 0.56 0.49	0.76	2.0	2.5	2.2	1.8	-	-	-	0.00063	40	
0.09 (0.125)	930	WU-DA71SG	0.70	0.40	-	<b>55.0</b> 52.0 47.0	<b>0.59</b> 0.50 0.40	0.93	1.7	2.5	1.9	1.5	-	-	-	0.00081	55	
0.12 (0.166)	900	WU-DA71SG	0.95	0.55	-	<b>53.0</b> 50.0 43.0	<b>0.59</b> 0.50 0.40	1.24	1.4	3.5	1.7	1.3	-	-	-	0.00081	55	
0.18 (0.25)	910	WU-DA71SK	1.3	0.75	-	<b>61.0</b> 59.0 53.0	<b>0.57</b> 0.50 0.39	1.87	1.7	3.0	1.9	1.5	-	-	-	0.00097	55	
0.25 (0.33)	920	WU-DA71SR	1.8	1.06	-	<b>61.0</b> 59.0 53.0	<b>0.56</b> 0.49 0.38	2.6	1.7	3.0	1.9	1.5	-	-	-	0.00124	55	
0.37 (0.5)	920	WU-DA80MG	2.2	1.27	-	<b>69.0</b> 68.0 64.0	<b>0.61</b> 0.51 0.40	3.8	2.0	3.7	2.2	1.8	-	-	-	0.0015	49	
0.55 (0.75)	920	WU-DA80MM	3.0	1.77	-	<b>71.0</b> 71.0 68.0	<b>0.63</b> 0.54 0.41	5.7	2.0	3.7	2.3	1.8	-	-	-	0.0021	49	
0.75 (1)	935	WU-DA90STX	IE2	3.8	2.2	-	<b>75.9</b> 73.8 70.1	<b>0.65</b> 0.54 0.44	7.7	2.9	4.8	3.0	2.5	-	-	-	0.0039	65
1.1 (1.5)	925	WU-DA90LWX	IE2	5.2	3.0	-	<b>78.1</b> 75.6 73.1	<b>0.67</b> 0.57 0.42	11.4	3.0	4.8	3.0	2.6	-	-	-	0.0043	65
1.5 (2)	930	WU-DA100LUW	IE2	7.3	4.2	-	<b>79.8</b> 76.8 74.6	<b>0.65</b> 0.54 0.43	15.4	2.0	4.2	2.6	2.0	0.63	1.3	0.63	0.011	58
2.2 (3)	950	WU-DA112MT	IE2	9.6	5.5	-	<b>81.8</b> 77.6 73.9	<b>0.70</b> 0.56 0.45	22.1	2.5	6.5	2.9	2.0	0.78	2.0	0.63	0.012	54
3 (4)	965	WU-DA132SLX	IE2	12.0	6.9	-	<b>83.3</b> 84.8 83.2	<b>0.75</b> 0.67 0.54	29.7	2.1	6.7	2.3	1.6	0.66	2.1	0.50	0.027	58
4 (5.5)	960	WU-DA132MMX	IE2	-	9.3	5.4	<b>84.6</b> 84.8 82.5	<b>0.74</b> 0.66 0.54	39.8	2.2	5.9	2.5	1.6	0.69	1.8	0.50	0.029	58
5.5 (7.5)	950	WU-DA132MRX	IE2	-	12.3	7.1	<b>86.0</b> 85.2 83.5	<b>0.75</b> 0.68 0.55	55.3	2.1	5.6	2.4	1.6	0.66	1.8	0.50	0.032	58
7.5 (10)	975	WU-DA160MM	IE2	-	16.6	9.6	<b>87.2</b> 88.1 86.2	<b>0.75</b> 0.67 0.56	73.5	1.8	6.5	2.8	1.7	0.56	2.0	0.53	0.10	59
11 (15)	980	WU-DA160LJ	IE2	-	24.0	13.8	<b>88.7</b> 90.0 88.5	<b>0.75</b> 0.67 0.57	107.2	2.0	7.5	2.8	1.9	0.63	2.3	0.59	0.12	59
15 (20)	980	WU-DA180LM	IE2	-	30.5	17.6	<b>89.7</b> 90.8 89.6	<b>0.78</b> 0.74 0.63	146.2	2.4	6.5	2.8	2.2	0.75	2.0	0.69	0.23	59

# Performance data

10

750 min<sup>-1</sup> (8 pole)

Rated power $P_N$ kW (hp)	Full load speed in revolutions per minute $n$ min <sup>-1</sup>	Frame reference and size Type	Full load current at rated voltage $I_N$			Efficiency $\eta$	Power factor $\cos \phi$	Full load torque $M_N$ Nm	Direct on line starting torque ratio $\frac{M_A}{M_N}$	Direct on line starting current ratio $\frac{I_A}{I_N}$	Direct on line pull out torque ratio $\frac{M_K}{M_N}$	Direct on line pull up torque ratio $\frac{M_S}{M_N}$	Star delta starting torque ratio <sup>1)</sup> $\frac{M_A}{M_N}$ Y	Star delta starting current ratio <sup>1)</sup> $\frac{I_A}{I_N}$ Y	Star delta starting current ratio pull up torque $\frac{M_S}{M_N}$ Y	Rotor inertia Wkg $J$ kgm <sup>2</sup>	Mean sound pressure level @ 1m on no load $L_{PA}$ dB(A)
			380 V A	400 V A	415 V A												
0.18 (0.25)	695	WU-DA80MG	1.01	0.96	0.96	<b>55.0</b> 52.0 44.0	<b>0.49</b> 0.42 0.34	2.5	2.2	2.7	2.5	2.0	-	-	-	0.0017	46
0.25 (0.33)	695	WU-DA80MM	1.26	1.2	1.2	<b>59.0</b> 56.5 49.0	<b>0.51</b> 0.43 0.34	3.5	2.2	2.9	2.5	2.0	-	-	-	0.0021	46
0.37 (0.5)	700	WU-DA90SG	1.71	1.63	1.63	<b>62.0</b> 59.0 51.0	<b>0.53</b> 0.44 0.34	5.1	2.3	3.0	2.5	2.1	-	-	-	0.0028	50
0.55 (0.75)	680	WU-DA90LM	2.4	2.3	2.3	<b>64.0</b> 62.0 55.0	<b>0.54</b> 0.44 0.33	7.6	2.3	3.3	2.7	2.1	-	-	-	0.0035	50
0.75 (1)	690	WU-DA100LR	2.77	2.64	2.64	<b>69.5</b> 68.0 61.0	<b>0.59</b> 0.49 0.40	10.4	1.8	3.2	2.1	1.7	-	-	-	0.009	53
1.1 (1.5)	690	WU-DA100LS	3.9	3.7	3.7	<b>71.5</b> 70.5 68.0	<b>0.60</b> 0.51 0.39	15.2	1.8	3.2	2.1	1.7	-	-	-	0.0095	53
1.5 (2)	690	WU-DA112MS	4.6	4.4	4.4	<b>74.5</b> 74.0 71.0	<b>0.66</b> 0.56 0.44	20.7	1.9	4.0	2.0	1.7	-	-	-	0.015	57
2.2 (3)	720	WU-DA132SM	6.2	5.9	5.9	<b>82.5</b> 83.0 80.0	<b>0.65</b> 0.57 0.45	29.2	1.6	5.0	2.4	1.5	-	-	-	0.029	57
3 (4)	720	WU-DA132MR	8.2	7.8	7.8	<b>84.0</b> 84.0 82.0	<b>0.66</b> 0.58 0.45	39.8	1.6	5.0	2.4	1.4	-	-	-	0.031	57
4 (5.5)	725	WU-DA160ME	10.4	9.9	9.9	<b>86.0</b> 86.0 84.0	<b>0.68</b> 0.64 0.51	52.7	1.6	5.5	2.5	1.4	0.5	1.7	0.45	0.09	53
5.5 (7.5)	725	WU-DA160MM	13.9	13.2	13.2	<b>87.0</b> 87.0 85.5	<b>0.69</b> 0.65 0.52	72.4	1.6	5.7	2.5	1.4	0.5	1.7	0.45	0.11	53
7.5 (10)	725	WU-DA160LV	18.2	17.3	17.3	<b>88.0</b> 88.0 86.0	<b>0.71</b> 0.65 0.52	98.8	1.6	6.0	2.5	1.4	0.5	1.8	0.45	0.14	53
11 (15)	730	WU-DA180LM	27.6	26.3	26.3	<b>90.0</b> 90.0 88.0	<b>0.67</b> 0.59 0.48	143.9	2.0	4.5	2.5	1.7	0.63	1.4	0.55	0.24	58

# Performance data notes

## Speed / torque, speed / current curves

### DOL starting

Typical speed/current curve

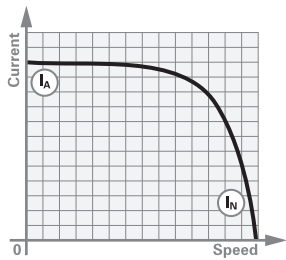

Typical speed/torque curve

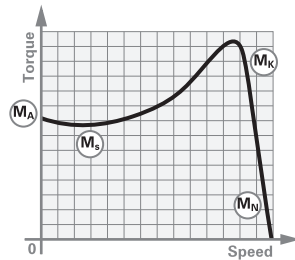

- (I<sub>A</sub>) Starting current
- (I<sub>N</sub>) Full load current
- (M<sub>A</sub>) Starting torque or locked rotor torque
- (M<sub>S</sub>) Pull up torque or run up torque
- (M<sub>K</sub>) Pull out torque or breakdown torque
- (M<sub>N</sub>) Full load torque

Torque/speed curves for specific motors can be supplied on request.

### Star delta starting

Typical speed/current curve

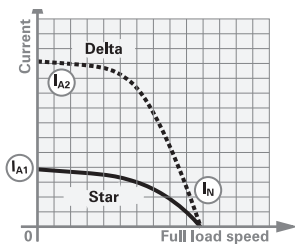

Typical speed/torque curve

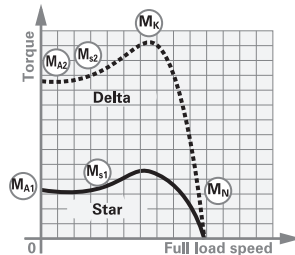

### Notes

During the run up period in Star, there must be an adequate excess of motor torque over the load torque. The change to Delta must not occur until the motor is near the operating speed.

Refer to Brook Crompton for running up against a load in excess of 70% full load during Star Delta starting.

Motors are wound for either 230/400 volts or 400 / 690 volts

Performance figures are subject to IEC tolerances. Performance figures are based on a 400 volt winding.

$$J \text{ (WK}^2 \text{ or WR}^2) = \frac{GD^2}{4}$$

$$J \text{ in lb ft}^2 = \frac{\text{kgm}^2}{0.042}$$

Where performance data indicates **IE2** or **IE3** 0.75kW to 22kW 2,4 & 6 pole within this catalogue, motor testing is in accordance with IEC 60034-2-1: 2007.

# Dimensions

12

Foot, flange and face mounting - frame sizes 63 to 180

IM B3  
IM 1001  
Mounting options

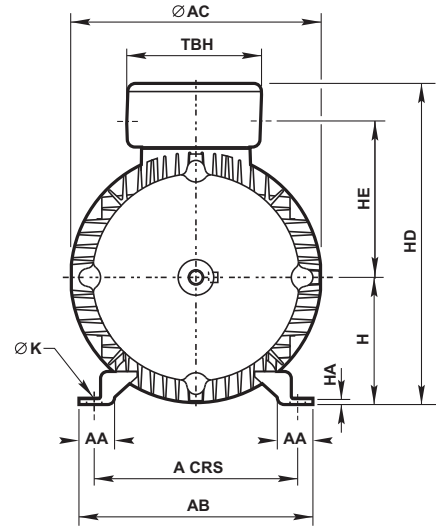
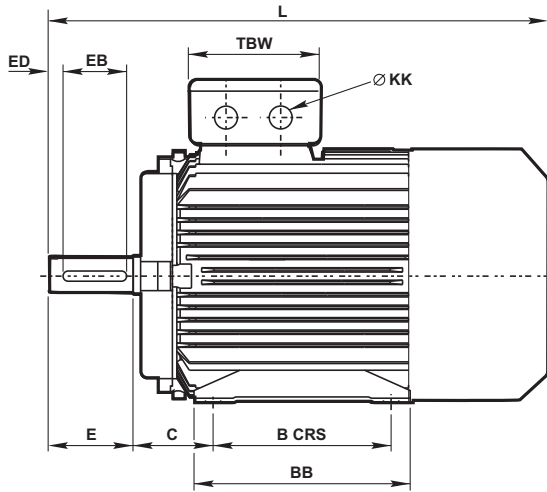

IM B5/IM B35  
IM 3001/IM 2001  
Mounting options

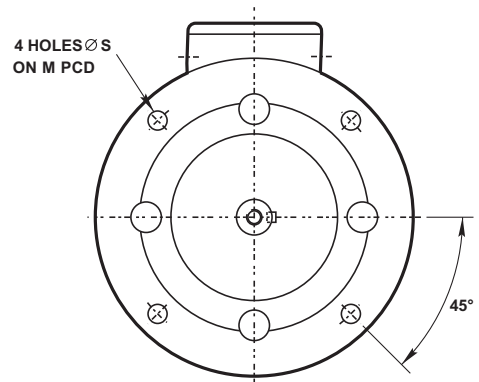
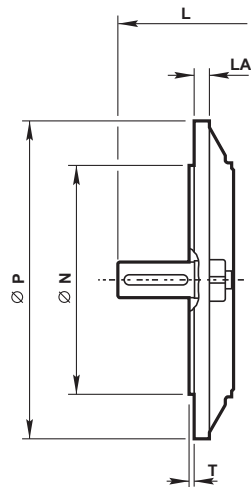

IM B14/IM B34  
IM 3601/IM 2101  
Mounting options

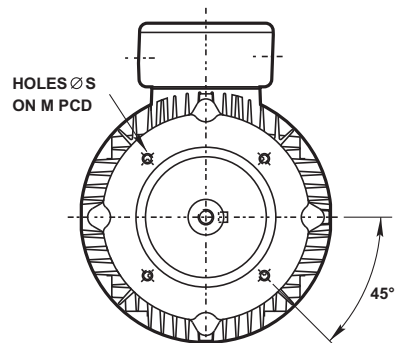
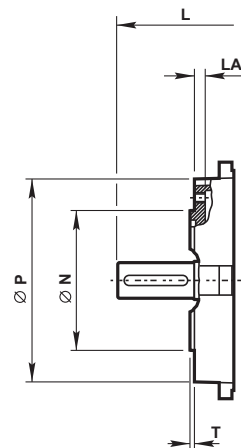

# Dimensions

Foot, flange and face mounting - frame sizes 63 to 180

General																	
Type																	Terminal box
Aluminium	A	B	C	H	K	L	L	AA	AB	AC	BB	HA	HD	HE	TBW	TBH	KK
WU-DA63S	100	80	40	63	7	207	207	19	119	126	100	2	163	75	86	86	1 x M20
WU-DA71S	112	90	45	71	7	238	238	19	131	140	110	2	186	91	86	86	1 x M20
WU-DA80M	125	100	50	80	10	278	278	27	157	160	127	4	212	103	86	86	1 x M20
WU-DA90S	140	100	56	90	10	349	322	28	164	178	150	4	225	111	86	86	1 x M20
WU-DA90L	140	125	56	90	10	349	322	28	164	178	150	4	225	111	86	86	1 x M20
WU-DA100L	160	140	63	100	12	368	368	28	184	199	170	4	254	123	106	106	2 x M20
WU-DA100LF	160	140	63	100	12	442	-	28	184	215	170	4	267	121	127	127	2 x M20
WU-DA100LW	160	140	63	100	12	379	-	28	184	199	170	4	254	123	106	106	2 x M20
WU-DA112M	190	140	70	112	12	382	382	35	218	215	170	4	279	133	127	127	2 x M25
WU-DA132S	216	140	89	132	12	489	451	38	242	255	208	5	323	157	127	127	2 x M25
WU-DA132M	216	178	89	132	12	489	451	38	242	255	208	5	323	157	127	127	2 x M25
WU-DA160M	254	210	108	160	15	605	605	49	304	314	304	5	400	196	140	140	2 x M32
WU-DA160L	254	254	108	160	15	605	605	49	304	314	304	5	400	196	140	140	2 x M32
WU-DA180M	279	241	121	180	15	667	667	50	329	358	329	6	440	216	140	140	2 x M32
WU-DA180L	279	279	121	180	15	667	667	50	329	358	329	6	440	216	140	140	2 x M32

Flange & Face													
Type	IM B5 mounting						IM B14 mounting						
Aluminium	M	N	P	S	T	LA	M	N	P	S	T	LA	
WU-DA63	115	95	140	10	3	7	75	60	90	M5	2.5	7	
WU-DA71	130	110	160	10	3.5	7	85	70	105	M6	2.5	9	
WU-DA80	165	130	200	12	3.5	12	100	80	120	M6	3.0	9	
WU-DA90	165	130	200	12	3.5	10	115	95	140	M8	3.0	9	
WU-DA100L	215	180	250	14.5	4.0	12	130	110	160	M8	3.5	12.5	
WU-DA100LF	215	180	250	14.5	4.0	12	130	110	160	M6	3.5	12.5	
WU-DA112	215	180	250	14.5	4.0	12	130	110	164	M8	3.5	13	
WU-DA132	265	230	300	14.5	4.0	12	165	130	200	M10	3.5	14	
WU-DA160	300	250	350	18.5	5.0	13	215	180	250	M12	4.0	13	
WU-DA180	300	250	350	18.5	5.0	15	-	-	-	-	-	-	

Shaft									
Type	D	E	F	G	GD	EB	ED	DH	
WU-DA63	11	23	4	8.5	4	10	0	M4 x 10	
WU-DA71	14	30	5	11	5	20	5	M4 x 12.5	
WU-DA80	19	40	6	15.5	6	32	4	M6 x 16	
WU-DA90	24	50	8	20	7	40	5	M8 x 19	
WU-DA100L	28	60	8	23.9	7	50	5	M10 x 22	
WU-DA100LF	28	60	8	23.9	7	50	5	M10 x 22	
WU-DA112	28	60	8	23.9	7	50	5	M10 x 22	
WU-DA132	38	80	10	33	8	70	5	M12 x 28	
WU-DA160	42	110	12	37	8	100	5	M16 x 36	
WU-DA180	48	110	14	42.5	9	100	5	M16 x 36	

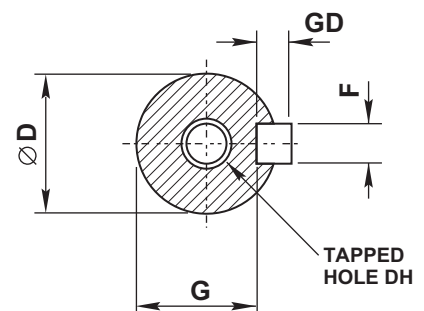

# Dimensions

## 14 Pad / rod mounting

IM B30, IM V30, IM V31  
IM 9201, IM 9211, IM 9231  
Mounting options

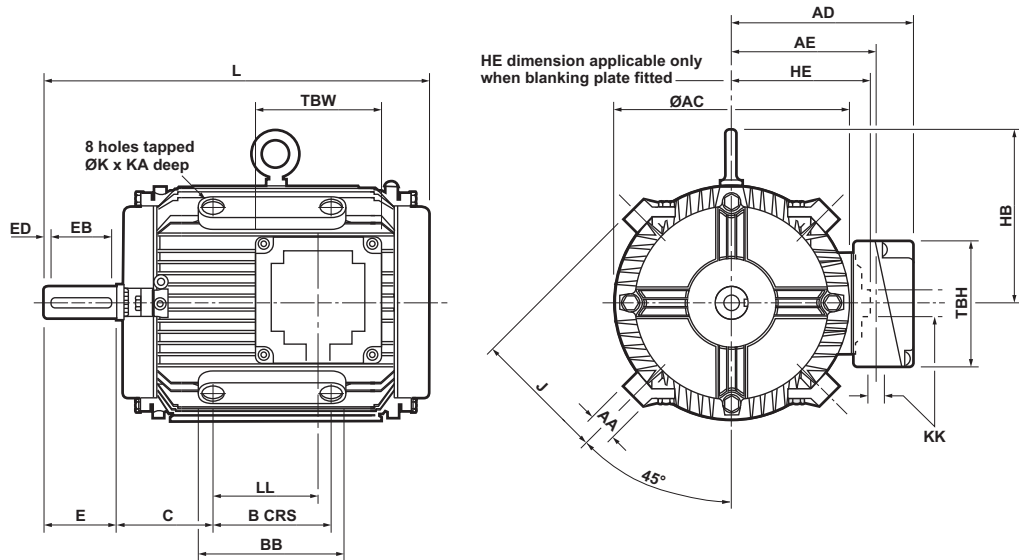

General																	
Type	B	C	AA	BB	J	L	L	AC	AD	AE	HE	LL	K	KA	Terminal box		KK *
Aluminium							$\phi$ pole								TBW	TBH	
WU-DA63S	90	45	18	119	70	180	180	126	100	75	73	37	M8	12	86	86	1 x M20
WU-DA71S	90	45	17	107	83.5	203.5	203.5	140	115	91	58	42	M8	12	86	86	1 x M20
WU-DA80M	90	55	18	120	95	253	253	160	132	102	102	70	M12	14	86	86	1 x M20
WU-DA90L	90	73.5	24	114	103	326	299	178	135	111	110	83	M12	13	86	86	1 x M20
WU-DA100L	100	83	24	124	112.5	320	320	178	154	123	116	88	M12	15	106	106	2 x M20
WU-DA100LF	100	90†	24	124	125	336	-	215	167	133	122	85	M12	18	127	127	2 x M20
WU-DA100LW	100	83	24	124	112.5	337	-	178	154	123	116	88	M12	15	106	106	2 x M20
WU-DA112M	100	90	24	124	125	336	334	215	167	133	122	85	M12	18	127	127	2 x M25
WU-DA132M	140	108	35	175	150	430	392	255	188	155	145	96	M16	19	127	127	2 x M25
WU-DA160L	200	135	35	225	181	533	533	314	239	196	175	158	M20	19	140	140	2 x M32
WU-DA180L	200	160.5	35	260	202	590	590	358	260	216	196	161	M20	19	140	140	2 x M32

\* one entry only, when motor is fitted with terminal plate  
† non standard dimension  
63 frame pad / rod mounting is not available with terminal box.

Shaft									
Type	D	E	F	G	GD	EB	ED	DH	
Aluminium									
WU-DA63	11	23	4	8.5	4	10	0	M4 x 10	
WU-DA71	14	30	5	11	5	20	5	M4 x 12.5	
WU-DA80	19	40	6	15.5	6	32	4	M6 x 16	
WU-DA90	24	50	8	20	7	40	5	M8 x 19	
WU-DA100L	28	60	8	23.9	7	50	5	M10 x 22	
WU-DA100LF	28	60	8	23.9	7	50	5	M10 x 22	
WU-DA112	28	60	8	23.9	7	50	5	M10 x 22	
WU-DA132	38	80	10	33	8	70	5	M12 x 28	
WU-DA160	42	110	12	37	8	100	5	M16 x 36	
WU-DA180	48	110	14	42.5	9	100	5	M16 x 36	

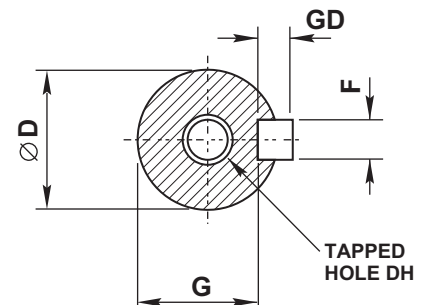

# Mounting options

## Horizontal shaft:

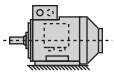

**IM B3  
IM 1001**  
foot mounted

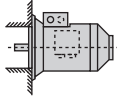

**IM B5  
IM 3001**  
flange at DE  
no feet



**IM B6  
IM 1051**  
foot wall mounted with  
feet on left-hand side  
when viewed from DE



**IM B7  
IM 1061**  
foot wall mounted with  
feet on right-hand side  
when viewed from DE



**IM B8  
IM 1071**  
ceiling mounted  
with feet  
above motor

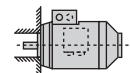

**IM B14  
IM 3601**  
face at DE  
no feet

## Vertical shaft:

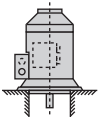

**IM V1  
IM 3011**  
flange at DE  
shaft down  
no feet

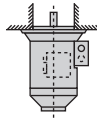

**IM V3  
IM 3031**  
flange at DE  
shaft up  
no feet

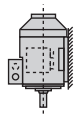

**IM V5  
IM 1011**  
vertical foot  
wall mounted  
shaft down

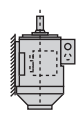

**IM V6  
IM 1031**  
vertical foot  
wall mounted  
shaft up

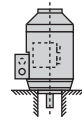

**IM V18  
IM 3611**  
face at DE  
shaft down  
no feet

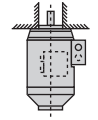

**IM V19  
IM 3631**  
face at DE  
shaft up  
no feet

## Approximate shipping specifications

Frame	Aluminium		Cubage [m <sup>3</sup> ]
	Net weight	Gross weight	
WU-DA63	5.0	5.4	0.01
WU-DA71	6.5	6.9	0.01
WU-DA80	12.0	13	0.02
WU-DA90S	13.0	14.0	0.03
WU-DA90SX	17.5	18.5	0.03
WU-DA90L	15.0	16.0	0.03
WU-DA90LX	20.5	21.5	0.03
WU-DA100L	24.5	27.0	0.038
WU-DA100LF	29.5	33.0	0.05
WU-DA100LW	25.0	27.5	0.038
WU-DA112M	29.5	33.0	0.05
WU-DA132S	46.5	51.5	0.071
WU-DA132SX	57.0	63.0	0.071
WU-DA132M	51.5	57.5	0.076
WU-DA132MX	60.5	66.5	0.076
WU-DA160M	84.0	94.0	0.125
WU-DA160L	92.0	102	0.125
WU-DA180M	116	131	0.253
WU-DA180L	126	141	0.253

Weights listed above are approximate and based on foot mounted [B3] standard design.

# Technical information

16

## Mechanical

Bearing arrangements and grease information

### Bearings and greasing arrangements

Bearings are pre-packed with a lithium complex based grease or Polyurea.

Regreasing facilities are available on request.

Standard and re-greasing facilities		
Type	Lithium complex	Polyurea
63 - 180	Esso Unirex N3 with temperature range of -30°C to +140°C	EA6 with a temperature range of -40°C to +160°C

Bearing references and oilseals					
Type	Poles	Bearings		Oilseals - bore x O/D x with (mm)	
		Drive end	Non-drive end	Drive end	Non-drive end
WU-DA63	All	6202ZZ	6202ZZ	15 x 24 x 5	15 x 24 x 5
WU-DA71	All	6003ZZ	6003ZZ	17 x 28 x 6	17 x 28 x 6
WU-DA80	All	6204ZZ	6003ZZ	20 x 30 x 7	15 x 24 x 5
WU-DA90	All	6205ZZ	6203ZZ	25 x 35 x 7	17 x 28 x 6
WU-DA100L	All	6206ZZ	6205ZZ	30 x 42 x 7	25 x 37 x 7
WU-DA100LF	All	6206ZZ	6205ZZ	30 x 47 x 7	25 x 37 x 7
WU-DA112	All	6206ZZ	6205ZZ	30 x 47 x 7	25 x 37 x 7
WU-DA132	All	6208ZZ	6305ZZ	40 x 52 x 7	25 x 37 x 7
WU-DA160	All	6309ZZ	6307ZZ	45 x 60 x 8	35 x 47 x 7
WU-DA180	All	6310ZZ	6308ZZ	50 x 65 x 8	40 x 52 x 7

Expected grease life at 80°C bearing temperature x 10 <sup>3</sup> hours								
Type	3000 min <sup>-1</sup>		1500 min <sup>-1</sup>		1000 min <sup>-1</sup>		750 min <sup>-1</sup>	
	Horizontal	Vertical	Horizontal	Vertical	Horizontal	Vertical	Horizontal	Vertical
WU-DA63	30	30	30	30	30	30	30	30
WU-DA71	30	30	30	30	30	30	30	30
WU-DA80	30	30	30	30	30	30	30	30
WU-DA90	30	30	30	30	30	30	30	30
WU-DA100L	30	30	30	30	30	30	30	30
WU-DA100LF	30	30	30	30	30	30	30	30
WU-DA112	30	30	30	30	30	30	30	30
WU-DA132	30	25	30	30	30	30	30	30
WU-DA160	29	19	30	30	30	30	30	30
WU-DA180	24	16	30	30	30	30	30	30



# Technical information

## Mechanical

### Axial and radial loads

Maximum permissible external axial and radial loads in Newtons *								
Type	Horizontal shaft			Vertical shaft				Maximum permissible radial load at end of shaft (horizontal mounting)
	Poles	Load towards motor	Load away from motor	Shaft up		Shaft down		
				Load towards motor	Load away from motor	Load towards motor	Load away from motor	
WU-DA63	2	324	480	316	491	335	472	434
	4	253	409	245	420	264	401	372
	6	280	436	272	448	292	428	396
WU-DA71	2	236	392	227	405	249	383	340
	4	207	363	196	380	224	352	314
	6	189	345	174	362	206	330	292
WU-DA80	2	339	539	321	565	362	521	774
	4	303	503	283	530	330	583	729
	6	284	484	260	516	316	460	646
	8	296	496	272	528	328	472	662
WU-DA90	2	444	684	421	716	476	661	915
	4	398	638	366	682	442	606	854
	6	349	589	309	641	401	549	720
	8	369	609	334	656	416	574	747
WU-DA100	2	781	1101	743	1159	839	1063	1295
	4	710	1030	655	1107	787	975	1215
	6	560	880	506	963	643	826	1145
	8	580	900	521	985	665	841	1018
WU-DA112	2	768	1088	715	1170	850	1035	1295
	4	690	1010	612	1131	811	932	1202
	6	541	861	463	979	659	783	1141
	8	565	885	487	1003	683	807	1009
WU-DA132	2	1355	1707	1266	1838	1486	1618	2114
	4	1253	1605	1130	1779	1427	1482	2068
	6	1167	1519	1035	1711	1359	1387	1968
	8	997	1349	858	1556	1204	1210	1600
WU-DA160	2	2144	2639	1951	2920	2425	2446	3613
	4	2123	2618	1895	2959	2464	2390	3738
	6	1973	2468	1669	2905	2410	2164	3544
	8	1464	1959	1144	2358	1863	1639	3233
WU-DA180	2	2711	3274	2465	3667	3104	3027	4374
	4	2749	3312	2426	3801	3238	2988	4556
	6	2575	3138	2166	3785	3222	2728	4334
	8	2266	2822	1850	3469	2906	2412	3979

\* All figures are based on L<sub>na</sub> bearing life of 20,000 hours. L<sub>na</sub> = adjusted L10 life rating taking account of:  
 • reliability • material improvements • lubrication conditions

# Dimensions notes

Shaft		
Dim D	Tol	Limits
11 to 14	j6	+0.008 -0.003
19 to 28	j6	+0.009 -0.004
38 to 48	k6	+0.018 +0.002
55 to 80	m6	+0.030 +0.011
85 to 110	m6	+0.035 +0.013

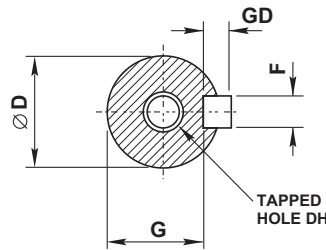

All dimensions in millimetres

Cable entry can be arranged in any one of four positions at 90° intervals

Dimensions should not be used for installation purposes unless specially endorsed

B5 mounted motors have suffix '-D' in the frame reference, eg WU-DA112MM-D and B3/B5 mounted motors have suffix '-H' in the frame reference, eg WU-DA112MM-H

B14 mounted motors have suffix 'C' in the frame reference, eg WU-DA112MM-C and B3/B14 mounted motors have suffix '-H' in the frame reference, eg WU-DA112MM-H

Dimensions should not be used for installation purposes, unless specially endorsed.

63 frame pad / rod mounting is not available with terminal box.

Flange		
Dim N	IEC 60072	
	Tol	Limits
110	j6	+0.013 -0.009
130	j6	+0.014 -0.011
230 to 250	j6	+0.016 -0.013
300	j6	+0.016 -0.016
350	j6	+0.018 -0.018
450	j6	+0.020 -0.020
550	j6	+0.022 -0.022
680	js6	+0.025 -0.025

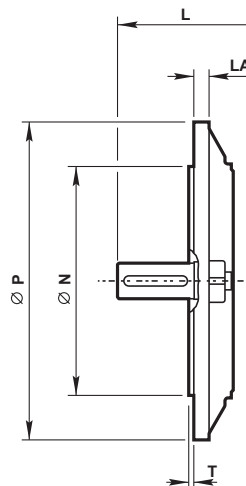

Face		
Dim N	IEC 60072	
	Tol	Limits
70 and 80	j6	+0.012 -0.007
95 and 110	j6	+0.013 -0.009
130	j6	+0.014 -0.011
230	j6	+0.016 -0.013

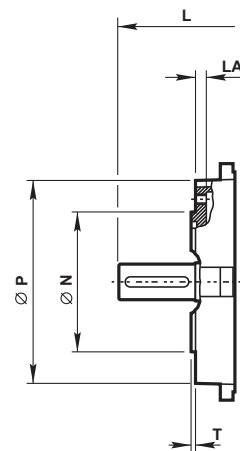



# BROOK CROMPTON

Brook Crompton UK Ltd  
St Thomas' Road Huddersfield  
West Yorkshire HD1 3LJ UK  
Tel: +44 (0) 1484 557200  
Fax: +44 (0) 1484 557201  
E-mail: [csc@brookcrompton.com](mailto:csc@brookcrompton.com)  
Internet: [www.brookcrompton.com](http://www.brookcrompton.com)

Every care has been taken to ensure the accuracy of the information contained in this publication, but, due to a policy of continuous development and improvement the right is reserved to supply products which may differ slightly from those illustrated and described in this publication

